

Warner Electric

Warner Linear

Matrix

Electric Clutches and Brakes for Wind Turbines

 **Altra**[®]
Industrial Motion





WARNER ELECTRIC, MATRIX AND WARNER LINEAR

provide a full range of electromechanical brakes and linear actuators for wind turbine applications. We specialize in customized solutions to meet the performance and installation requirements for this specific market (performance, reliability, low consumption and cost efficiency).

Between these three brands, we have over 100 years experience delivering technically advanced, cost effective braking and positioning systems.

Depending on the application, we can serve large wind turbines, but also small and medium HAWT & VAWT markets.

We offer production, engineering and application support from our facilities in Europe, the US and Asia.

But it doesn't stop there... additional power transmission products – including hydraulic pneumatic brakes, high-performance couplings, and overrunning clutches, are available from our sister companies within Altra Industrial Motion.



Caliper Brakes

by Warner Electric

VAR 11 is an electrically released failsafe caliper brake which offers a cost effective solution for holding, static and/or emergency stops. Can be used in either a horizontal or vertical position.



Electrically Released Brakes

by Warner Electric and Matrix

Spring-set designs are available for stopping or holding a load in the event of a power failure; or choose permanent magnet designs for dynamic emergency stopping.



Controls

by Warner Electric

Our range of power supplies are designed for low consumption brakes. For instance, only 6 watts for a VAR 11-11 caliper brake, 450 mm disc for 440 Nm torque.



Linear Actuators

by Warner Linear

Our broad range of standard actuators can be custom configured to meet specific applications including special pin to pin and stroke lengths, special end fittings, mounting brackets, paints, and lead wire lengths. They are designed for access hatch and pitch drive. Load capacity up to 12,700 N.



OUR PRODUCTS HELP YOU MAKE YOUR WIND TURBINE SAFE AND IN CONFORMITY WITH:

BWEA, AWEA 9,1 – 2009 standards
IEC 61400-2 standard



Wind Turbine			ECB Products				
Range Actuators	Type	Application	Caliper Brakes	Power-Off Brakes	Electro-mechanically Actuated Brakes (custom designed)	Linear	
Medium & Large (Medium: from 100 kW to 600 kW; Large: up to 600 kW)	HAWT	Pitch Drive Brake	•				
		Pitch System				•	
		Wing Tip	•				
		Wing Lock				•	
		Low Speed Shaft Rotor Brake			•		
		High Speed Shaft Rotor Brake			•		
		Rotor Lock					•
		Yaw Drive Brake	•		•		
		Yaw Brake (Azimuth Disc Brake)					
		Yaw Lock					•
		Ventilation/Service Hatches Motion in the Nacelle					•
		Access Gates Motion to the Nacelle					•
		Wind Elevator Motor		•	•		
Small (Less than 100 kW)	HAWT	Rotor Brake	•	•			
	VAWT	Rotor Brake	•	•			

HAWT = Horizontal Axis Wind Turbine
 VAWT = Vertical Axis Wind Turbine

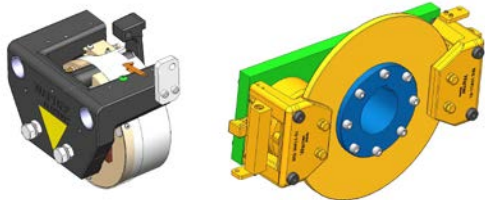

Linear electric actuators

K2, K2X, A-track, S-track & M-track

- High force : up to 12 700 N
- Stroke : 4,6,8,12,18,24 inches (higher is possible on request)
- Voltage : 12, 24 Vdc – 115, 230 Vac
- Strong construction with acme or ball screw
- Electrical protection up to IP65
- Ambient temperature : - 26°C / + 65°C
- Adjustable limit switches (optional)
- Stroke position feedback (optional)
- Motor auto-reset thermal protection



VAR 11-11

Spring applied, electrically released caliper & disc brake

- High Torque : up to 770 Nm on a 450 mm OD disc
- Low power consumption : down to 6 watts
- Voltage : single voltage 24 Vdc, dual 207/103,5 Vdc dual 103,5 / 52 Vdc, dual 103,5 / 26 Vdc
- Insulation of magnet : class F (155°C)
- Strong construction with metal rotor
- Electrical protection IP54 (higher possible on request)
- Corrosion protection C2 or C3 (C5 optional)
- Ambient temperature : - 20°C / + 40°C
- Micro-switch IP66 (optional)
- Hand release lever (optional)

Rotor disc brake

Access Hatches

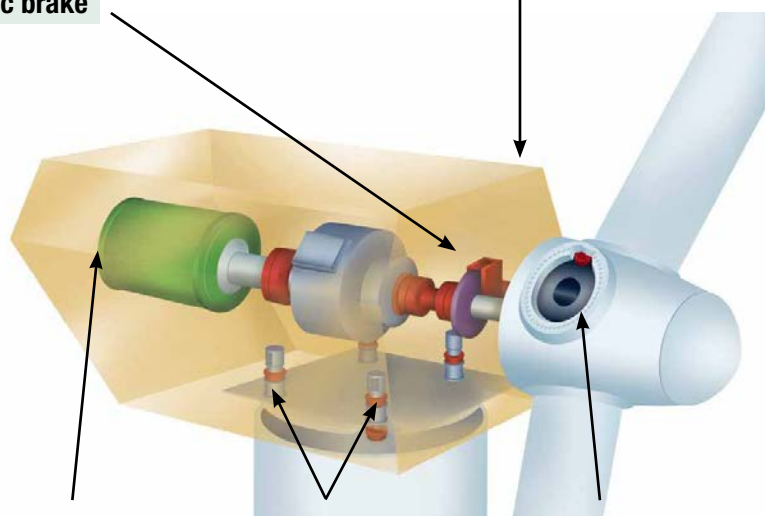

Rotor shaft brake

Yaw motor brake

Pitch motor brake

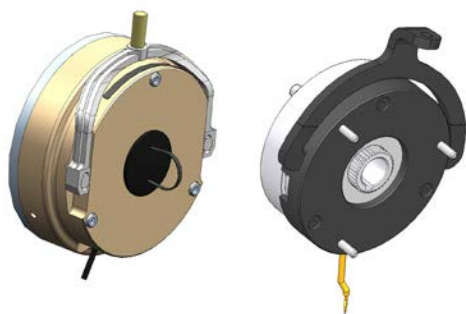

Closed design ERD, 1EB & PK brakes series

Spring applied, electrically released brake

- Torque range : 30 to 400 Nm
- Voltage : single voltage 24 Vdc, dual 207/103,5 Vdc, dual 103,5 / 52 Vdc
- Insulation of magnet: class F (155°C)
- Strong construction with metal rotor
- Fully closed design with seals
- Protection level IP54 to IP65 according to configuration
- Corrosion protection C3 to C5 according to configuration
- Ambient temperature: -20°C/+ 40°C (other possible on request)
- Micro-switch IP66 (optional)
- Hand release lever (optional)



Warner Electric

New Hartford, CT - USA
1-800-825-6544
St Barthelemy d'Anjou, France
+33 (0) 2 41 21 24 24

Warner Linear

Belvidere, IL - USA
1-800-825-6544
St Barthelemy d'Anjou, France
+33 (0) 2 41 21 24 24

Matrix

Brechin, Scotland
+44 (0) 1356 602000
New Hartford, CT - USA
1-800-825-6544